

DELTAGER GUIDE



KØGE JERNMAND 2026

SJF BANK

KØGE
TRI-TEAM
2000

TRIALTON
DANMARK

STOR TAK TIL VORES SPONSORER

WATERY

ENERVIT
The Positive Nutrition Company

SKOVLYST
RYG

REMA 1000

ES ENDURANCE SPORT
COPENHAGEN

Table of Contents

Race Guide	1
Practical Information	2
Overall Schedule:	2
Friday:.....	2
Saturday:.....	2
Sunday:.....	2
Result Service	3
Facebook, Instagram and website	3
Medals & prizes.....	3
REMEMBER to be well prepared	3
Public transport	4
Parking	4
Photo service	4
Start area and transition area	5
Harbor area / surrounding area	5
First aid	5
Race number and Check-in.....	5
Friday:	6
Saturday:.....	6
Sunday:	6
Race number collection.....	6
Transition area	6
Before bike check-in	7
Changing rooms and toilets.....	7
The transition area	7
Changing.....	8
Timing chip and race number	8
Elite race number	9
Race execution	9
Relay	9
Watery swim courses.....	9
Short-distance swim course	10
Middle-distance swim course	10
Swim start timetable	11
Swim cut-off.....	11

Safety on the swim course.....	11
Warm-up.....	12
Læssøe Mandskab bike course	13
Køge short distance:	14
Køge middle distance & Aquabike:.....	14
Traffic on the bike course.....	15
Drafting and overtaking	15
Music	15
Officials	16
Enervit aid station on the bike course	16
Transition area, T2.....	16
Bike course cut-off.....	16
Bryggeri Skovlyst - Run course.....	17
Aid stations	18
Litter and penalty.....	18
Run course cut-off.....	19
Signage.....	19
Spectators.....	19
Race organizer / Disclaimer	20
Sponsors.....	20

Race Guide

Welcome to Køge Jernmand 2025.

It is with great pleasure that Køge Tri Team 2000 once again welcomes you to Køge Jernmand – this year for the fourth time, and once again as host of the Danish Championships in middle distance and aquabike.

To enhance the experience even further, we have updated the bike course this year for the benefit of both participants and spectators. The new course consists of a longer loop, where the short distance completes one lap and the middle distance completes two laps.

In this race guide, you will find the most important information leading up to race day – whether you are competing in your first triathlon or have plenty of race experience.

We recommend that you read this guide carefully so that you are as well prepared as possible and get the best possible experience at Køge Jernmand.

If you have any questions, you are always welcome to contact us via our Facebook page and Messenger:

www.facebook.com/koegejernmand

We look forward to welcoming you to a day filled with atmosphere, community, and strong performances. Whether you are chasing a podium place or fighting to cross the finish line, you are an important part of the experience – and a true winner.

Kind regards

On behalf of Køge Jernmand & Køge Tri Team 2000

Michael Mark
Race Director & Chairman

Practical Information

Overall Schedule:

Friday:

16:00 The Theatre Building at Kulturtorvet opens for race number collection.

20:00 The Theatre Building at Kulturtorvet closes for race number collection.

Saturday:

09:00 The Theatre Building at Kulturtorvet opens for race number collection.

Several of our sponsors will have booths open with great offers and those last items you might still need for race day.

16:00 The Theatre Building at Kulturtorvet closes for race number collection.

Sunday:

OBS OBS OBS – Der er meget kort tid til afhentning af startnumre søndag morgen, og det anbefales derfor ikke.

06:30 The Theatre Building at Kulturtorvet opens for race number collection.

07:30 The Theatre Building at Kulturtorvet closes for race number collection.

07:30 Check-in opens at the harbor.

08:45 10-minute warm-up in the transition area with SATS Køge

09:00 Check-in in the transition area at the harbor closes

09:10 The transition area closes.

09:15 Welcome by Kirsten Larsen, Chair of the Culture and Sports Committee of Køge Municipality

09:25 Short race briefing at the swim start for everyone

09:30 Swim start for the short distance, including the short relay.

09:45 Race briefing at the swim start for middle distance and Aquabike.

10:00 Swim start for middle distance Elite + AG + Aquabike + middle relay.

12:20 Swim course cut-off; everyone must be out of the water.

15:00 Award ceremony at Kulturtorvet for Elite and ongoing for age-group athletes

18:00 The last runner is expected to finish.

There is no access to the harbor area or the transition area before 07:30.

Changing rooms and toilets also open only at 07:30.

The cut-off times must be observed. If you exceed the time limit, you may not continue. If you are registered for the middle distance and are unsure whether you can finish within the time limit, contact an official at check-in. You may be moved to the short distance, but this depends on participant numbers and attendance and therefore cannot be guaranteed.

Result Service

In cooperation with Sportstiming, we offer professional results services. Online timing will be available via <https://www.sportstiming.dk/event/16213>

Facebook, Instagram and website

You can find Køge Jernmand on [Køge Jernmand | Køge | Facebook](#), where all news and other relevant information will be posted, and on [Instagram](#). You can ask the organizers questions before race day via Facebook Messenger. GPX files for the routes can be found at [Routes - Strava](#).

Please share your posts and tag Køge Jernmand on social media. Feel free to use these hashtags: #kj2026 #køgejernmand #køgejernmand2026 #køgejernmand2026

Medals & prizes

The award ceremony starts at 15:00 at Kulturtorvet for the Danish Championships middle distance Elite field, as well as the Danish Championships Aquabike.

In addition, there will be medals for everyone who completes Køge Jernmand. The medal will be presented when you cross the finish line, together with sponsored drinks – and once again this year there will be a barbecue and food available. If you are competing in a relay, please make sure that **all** relay participants are near the finish line, as this is where the medal is presented. Danish Championship Aquabike participants will receive their finisher medals when they finish the bike leg.

Thanks to our generous sponsors, there is a chance to win prizes. There will be prizes for the top three men and women in the overall standings for both distances, as well as great raffle prizes for everyone.

For the Elite field, there are cash prizes for women and men for the top 5, distributed as follows:

- | | |
|----|-----------|
| 1. | 7,500 DKK |
| 2. | 6,250 DKK |
| 3. | 5,000 DKK |
| 4. | 3,750 DKK |
| 5. | 2,500 DKK |

Rules

The race is organized as a championship event under the Danish Triathlon Federation. Participants in the elite field must pay special attention to the specific requirements and ensure that they are familiar with them in advance. The rules can be found here: [20260416-01 Competition Rules](#)

REMEMBER to be well prepared

Read this guide carefully and remember that it is your own responsibility to know T1/T2, the swim, bike, and run routes.

It is better to bring too much clothing than too little, so keep an eye on the weather forecast.

Public transport

We encourage everyone who can to use public transport, as there are good opportunities to reach Køge by train. S-trains run to Køge Station, which is located 500 m from the start area. In addition, Køge Nord offers direct connections to express trains from Jutland and Copenhagen, as well as connections to the S-train network.

Parking

For those arriving by car, we ask that traffic regulations are respected so you avoid fines and do not inconvenience the town's residents.

Where can you park

Please note that parking at the harbor is not permitted. In Figure 1, you can see the most central parking options marked in blue.

The blue areas are:

Parking at Rådhusstrædet 12B (parking garage), the parking lot behind Haverne, and parking at Toldbodvej (gravel area). Remember to check for any paid parking zones.



Figure 1: Parking area

Photo service

There will be photographers at selected locations throughout the day, and the photos will afterwards be made available free of charge on our Facebook page.

Start area and transition area

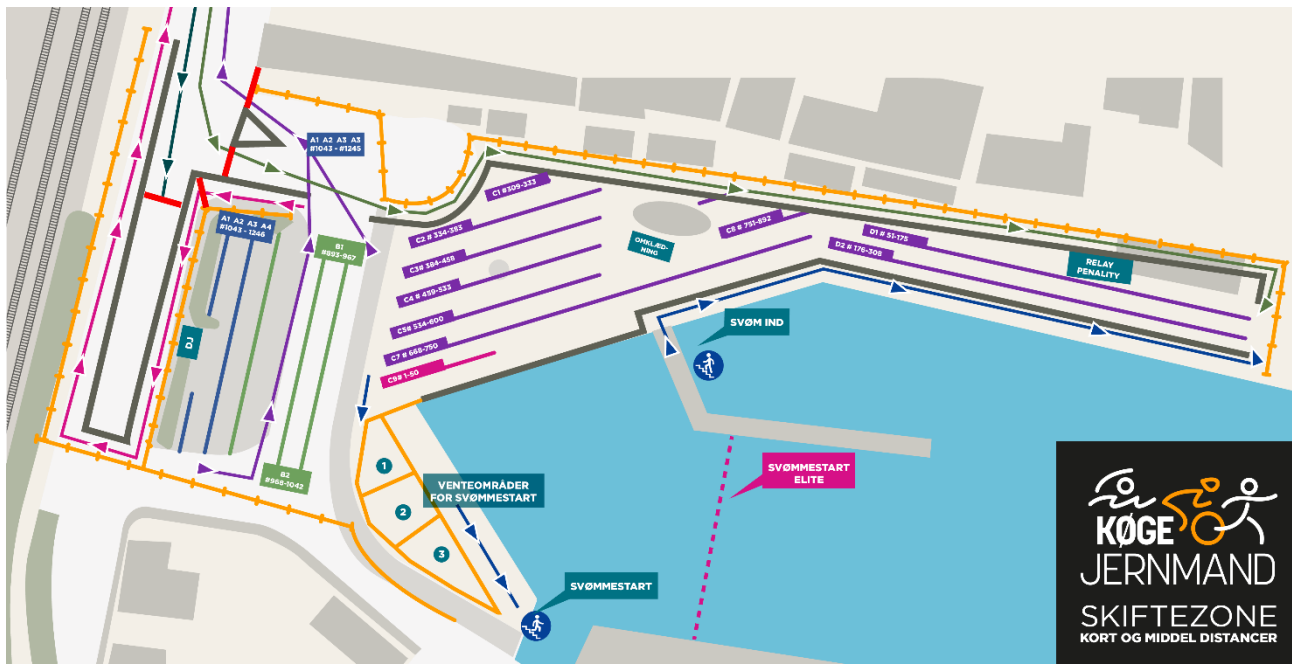

Figure 2: Transition area T1/T2

Harbor area / surrounding area

In the harbor area there are several restaurants where food and drinks can be purchased. Køge town can be reached by crossing the railway crossing, where there are opportunities for shopping, entertainment, and access to the run course and finish area. At the harbor and Kulturtorvet, a number of our sponsors will be represented, including our main sponsor SJF Bank, so please stop by and visit them.

First aid

First aid personnel will be available throughout the race at Kulturtorvet. On the bike course, first aid responders will be ready on motorcycles. All officials are in contact with the first aid team, so in case of an accident you should contact an official, who will be able to get help as quickly as possible.

Race number and Check-in

Race number collection is available on Friday, Saturday (the day before the event), and Sunday (on race day).

VI OPFØRDER KRAFTIGT TIL AFHENTNING LØRDAG DA TIDEN ER MEGET KNAP SØNDAG MORGEN.

When collecting your race number, you must present valid photo ID and your license pass (printed or on your phone). This is to help you avoid unnecessary stress on race morning.

Relay teams **must arrive together** for collection, as **all participants must wear a wristband**. **It is not possible to collect race numbers on behalf of others.**

REMEMBER to collect your participant T-shirt if you have ordered one. This must be done together with race number collection.

Friday:

This year, the Theatre Building will already open for race number collection between 16:00 and 20:00. This is exceptional, as we have reduced the available time on Sunday morning. At check-in you must present valid photo ID and your license pass (printed or on your phone). On the back of the race number provided, you must write contact details for your next of kin so we can notify them in case of an accident.

Saturday:

The Theatre Building will be open, and it will be possible to collect your race number between 09:00 and 16:00. We strongly encourage everyone to collect their race number on Saturday so you can avoid stress on race day itself. At check-in you must present valid photo ID and your license pass (printed or on your phone). On the back of the race number provided, you must write contact details for your next of kin so we can notify them in case of an accident.

Sunday:

Race number collection

Collection on race day takes place in the Theatre Building at Kulturtorvet, the area west of the transition zone and right by the finish area. Race number collection is open from 06:30 to 07:30. At check-in you must present valid photo ID and your license pass (printed or on your phone). On the back of the race number provided, you must write contact details for your next of kin so we can notify them in case of an accident.

Transition area

The transition area opens at 07:30. We recommend that you arrive in good time so you have time to find your place in the transition area and avoid stress and confusion immediately before the swim start.

There will be helpers in the transition area. You can recognize them by their yellow vest or by white shirts with "Organizer" printed on the back. Their instructions must be followed. They can also answer questions about the transition area or other general questions about the event, but they are **not** your race guide.

We also recommend that you familiarize yourself with the transition area before the start and, not least, remember where your bike is placed. All bike positions are numbered – see Figure 2.

Check-in must be **completed** before 09:00.

Together with your race number you will receive the registration envelope containing the timing chip and chip holder (Velcro strap).

- Swim cap, delivered together with the A5 envelope; see the swim start schedule for cap color on page 11.
- Race number (not for Elite, where tattoos are used, nor for Aquabike)

- Safety pins (4 pcs.)
- Number stickers for your bike helmet
- Number stickers for your bike
- Number sticker for your transition bag/box
- Participant wristband (must be worn to enter and leave the transition area and to collect your bike after the race)

Before bike check-in

Before you are allowed to enter the transition area, you must place all stickers on your bike, transition box, and bike helmet, and add emergency contact details on the back of your race number. You must then show your participant wristband on your wrist, after which you may place your bike in the assigned numbered position.

A bike helmet is mandatory during the bike leg. The helmet must be CE-marked. It must not have cracks or similar damage, as it would then not protect effectively. Officials may reject any helmet that does not meet the requirements, and a new helmet must then be provided before access to the transition area can be granted.

It is also your own responsibility to ensure that your bike is in good condition, including making sure that it meets the current braking requirements so the bike is safe to ride.

Changing rooms and toilets

Changing facilities are available at the Theatre Building by check-in or in the changing tent in the transition area, and toilets are also available in the transition area.

The transition area

After check-in, you must place your bike in the designated racks in the transition area. You must position the bike according to the instructions from the officials in T1/T2; the bikes must be placed alternately facing east and west and hung by the saddle. Follow the officials' instructions and place the bike at your race number.

The transition box is provided at check-in and must be placed by your bike on the right side of the front wheel. It must be clearly marked with a number sticker and must contain all the equipment you need to complete the race.

Only the helmet may be left on the bike; everything else must be placed in the transition box. Cycling shoes must either be attached to any clip-in pedals or placed in the transition box. No equipment other than the transition box may be placed on the ground by the bike.

Luggage and spare clothes can be left at the Theatre Building. You will find this at check-in. Luggage is accepted ONLY if it is marked with your race number. Luggage is supervised throughout the event, but Køge Jernmand does not accept responsibility for deposited luggage.

The transition area is a restricted zone monitored by officials. You can collect your bike from 16:00. To remove the bike, you must show the race number you wore during the race as well as your participant wristband. Therefore, do not remove your race number, bike number, or wristband until you have left the transition area.

For safety reasons and to reduce the risk of theft, only participants and officials wearing participant wristbands are allowed access to the transition area. Family and friends are welcome to stay along the barriers, but they may not enter the area. The transition area is closed during the race and until 16:00. In special cases, permission may be granted to collect a bike and equipment earlier if activity in the transition area allows it. Always show consideration for other triathletes in the area.

It is not permitted to mark your bike with balloons or similar items.

Changing

Changing in the transition area can take place in the transition tent, which will be divided into a men's and a women's side. You are of course also welcome to change clothes by your bike, but please note that nudity is not permitted in the transition area.

There will be two places for changing: at check-in in the Theatre Building and in the transition area. The transition tent is located in the middle of the transition area by the stage. If the transition tent is used, you must collect your change of clothes from your bike and take them back to the tent. After changing, you must take your clothes back to the bike and place them in the transition box. Please note that no clothing may be left in the transition tent; it must be placed in your transition box.

Timing chip and race number

The timing chip must be attached to the chip holder provided for it (Velcro strap), which must be fastened around your ankle. For timing purposes, it is important that the chip is placed on the ankle and not elsewhere on the body. The timing chip must be attached before the swim start and must be worn throughout the event. The chip is handed out at check-in and must be returned immediately after you cross the finish line. If you withdraw during the race, it is your responsibility to return the chip to an official.

The race number for the bike helmet must be placed visibly on both the right and left side as well as on the front of the helmet, as shown in the image below:

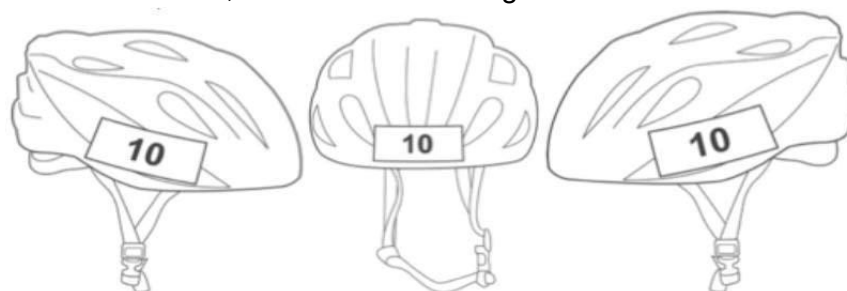

The race number for the bike must be placed on the seat post or brake cable, as shown in the image below:

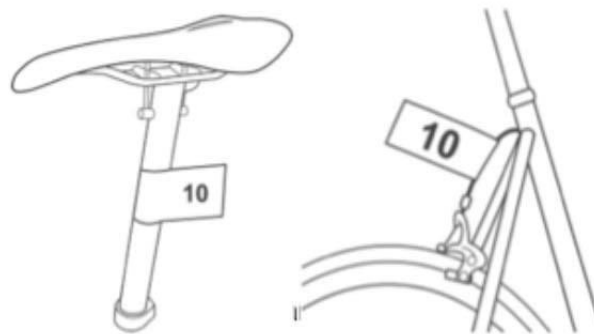

During the run leg, the race number must be worn visibly on the front of the body. It is permitted, but not required, to wear the race number during the bike leg as well. However, the race number must not be worn during the swim. The number must be kept in the transition box so that it is ready to be put on either at the bike start or the run start. You may benefit from bringing a race belt to which the number can be attached in advance. This way, you do not need to spend time fastening the number to your clothing during transition. Please note that the number must be on before you leave the transition area.

Elite race number

Participants in the Danish Championship elite field must not wear or attach race numbers. Instead, they must compete in a trisuit that complies with WT rules and has their name displayed. If you do not have such a suit, you must apply for an exemption from Triathlon Danmark before the race by email. If you arrive on race day without your name on the suit, the head referee will decide the matter and may choose to grant an exemption, but you should have applied in advance. In addition, tattoos will be provided, which must be placed with one on each arm.

Race execution

Relay

The following applies only to relay participants, i.e. swimmer, cyclist, and runner on a team. All changes must take place in the relay transition, see Figure 2. It is the team's own responsibility to be ready in the relay transition when the previous participant has finished. You may not continue until the chip has been handed over to the next participant. The swimmer must finish the swim and run to the relay transition, where the chip is handed over, after which the cyclist may run to the bike; cycling shoes and helmet must be by the bike. At the end of the bike leg, the cyclist must place the bike back in its original place and run to the relay transition where the runner will be ready. The chip must be handed over, and the runner must remember to wear the race number on the front of the body.

Watery swim courses

There are two different routes for the short and middle distances respectively. See Figure 3a and Figure

3b. Both routes start from the harbor, the same place where T1/T2 and the race briefing are also held. The swim start is conducted by sending a number of athletes off at suitable intervals; officials give the signal, after which the triathlete walks down the stairs and jumps into the water from 0.5 m and begins swimming. The time starts only the moment the mat is

crossed.

The Elite field has a mass water start, which takes place by swimming over the lane rope.

Short-distance swim course

The short-distance swim follows the course shown in Figure 3a, an out-and-back route of approx. 950 m. The triathlete swims to the right of the buoy in the water. Exit is at the pontoon bridge by T1/T2; run from the pontoon/floating bridge and directly onto the route into T1/T2.

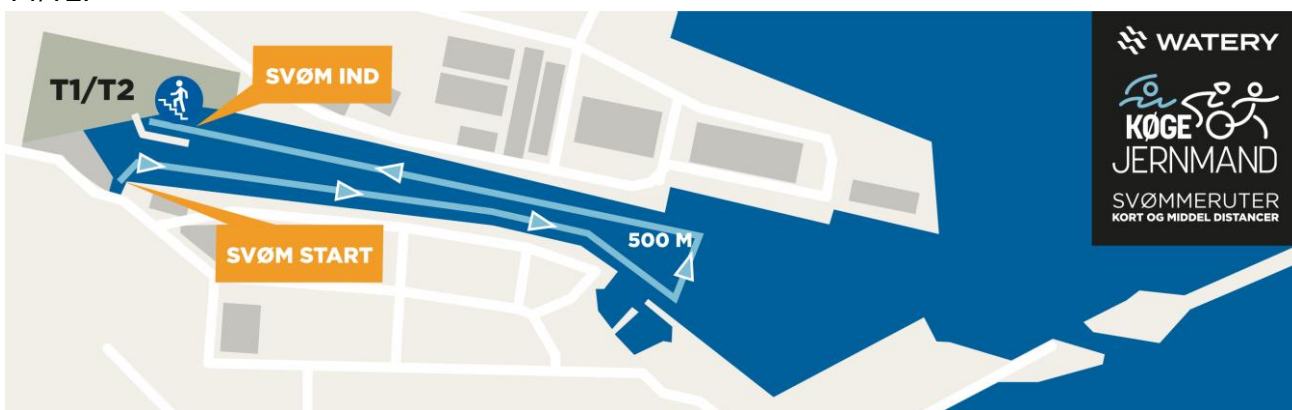

Figure 3a: Short swim course

Middle-distance swim course

The middle-distance swim follows the course shown in Figure 3b, an out-and-back route of approx. 1900 m. The triathlete swims to the right of the buoy in the water. Exit is at the pontoon bridge by T1/T2; run from the pontoon/floating bridge and directly onto the route into T1/T2.

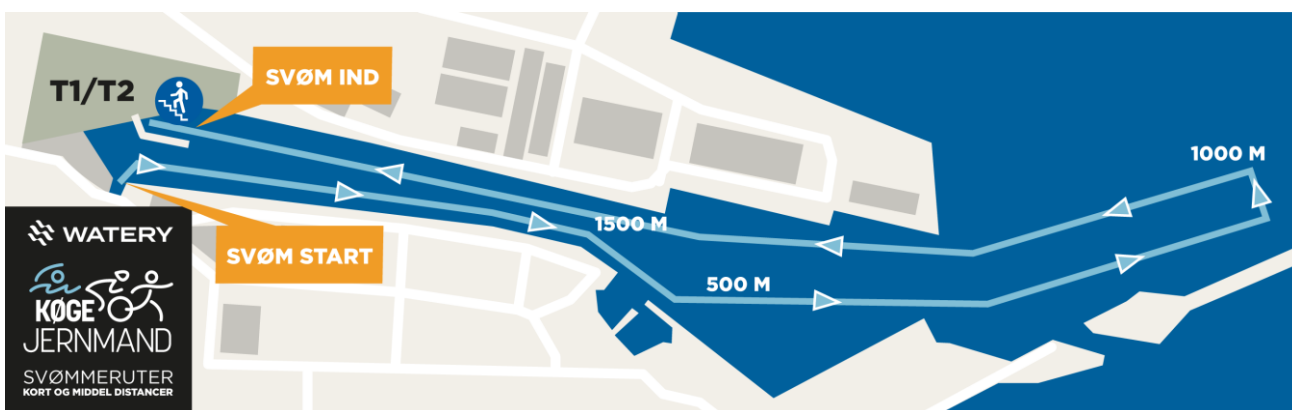

Figure 3b: Middle swim course

Swim start timetable

Tidstabel for svømmestart		STARTBOKSE					BADEHÆTTE
GRUPPE	STARTTID	Cutoff Svøm	Startboks 1	Startboks 2	Startboks 3	Startboks 0 / sluse	Badehættefarve
Kort distance 1	09:30	10:15	09:15 Startboks 1			09:25 Sluse / start	Gul
Kort distance 2	09:40	10:25		09:25 Startboks 2		09:35 Sluse / start	Blå
Stafet kort	09:45	10:30			09:30 Startboks 3	09:45 Sluse / start	Hvid
Elite	10:00	11:20	09:40 Startboks 1			09:50 Sluse / start	Rød
AG 18-24	10:05	11:25		09:50 Startboks 2		10:00 Sluse / start	Grøn
Aquabike + Middel stafet	10:10	11:30			09:55 Startboks 3	10:05 Sluse / start	Gul
AG 25-29 Herrer	10:15	11:35	10:00 Startboks 1			10:10 Sluse / start	Sort
AG 30-34	10:30	11:50		10:15 Startboks 2		10:25 Sluse / start	Blå
AG 35-39	10:40	12:00			10:25 Startboks 3	10:35 Sluse / start	Hvid
AG 40-49	10:50	12:10	10:35 Startboks 1			10:45 Sluse / start	Grøn
AG 50+ / 25-29 Kvinder	11:00	12:20		10:45 Startboks 2		10:55 Sluse / start	Sort

Køge Jernmand uses a rolling swim start to give all participants the best possible experience and a good flow from the start area. The times stated in the race guide are therefore “not before” times. This means that your age group will start no earlier than the time shown, and small pauses may therefore occur in the rolling start. We recommend that all participants are ready in the start area well in advance so you are prepared when it is your turn to start the race!

It is important to start in the correct start group. The penalty for starting in an earlier start group is DSQ.

Swim cut-off

The swim cut-off time is 1 hr 20 min for the middle distance and Aquabike, and 45 min for the short distance. Participants who have not completed the swim within this time will be disqualified and may not continue onto the bike course.

Safety on the swim course

During the swim there will be SUP boards and kayaks in the water to ensure your safety. If you have problems during the swim, make a clear signal and you will receive help immediately.

The water temperature is expected to be below 22 degrees, and therefore a wetsuit must be used (as a general rule, we refer to the 2026 Danish Triathlon Federation competition rules, section 4.2 on the use of wetsuits). The water temperature is expected to be between 16°C and 20°C, which is why the maximum time in the water is limited to 45 minutes for the short distance and 1 hr 20 min for the middle distance.

Decisions about any changes due to temperature, wind, or waves are made by the organizer in cooperation with the Technical Delegate from Triathlon Danmark. If the distances are changed, the cut-off times will also be changed.

The swim cap provided must be worn, although it is permitted to wear an extra swim cap under the provided swim cap. Swim fins, snorkels, hand paddles, swim buoys, neoprene gloves, neoprene socks/booties, or other aids are not permitted. A neoprene cap is, however, allowed (max 5 mm).

Warm-up

Warm-up is permitted until 09:15. Swim warm-up must **NOT** take place on the swim course, but **MUST** take place south of the start arch in the warm-up area. Strong waves or current conditions may mean that the swim course is changed. If this happens, the triathletes will be informed at check-in.

We refer you to open-water swim safety:

- Do a thorough warm-up on land
- If relevant, do a short warm-up in the water before the start
- Keep focus on your body temperature
- Make sure your heart rate is appropriate and that you have enough energy before the swim start
- Avoid stress during the swim start
- Wetsuit is mandatory for all participants

Your swim time ends when you cross the timing mat at the pontoon bridge at the swim exit.

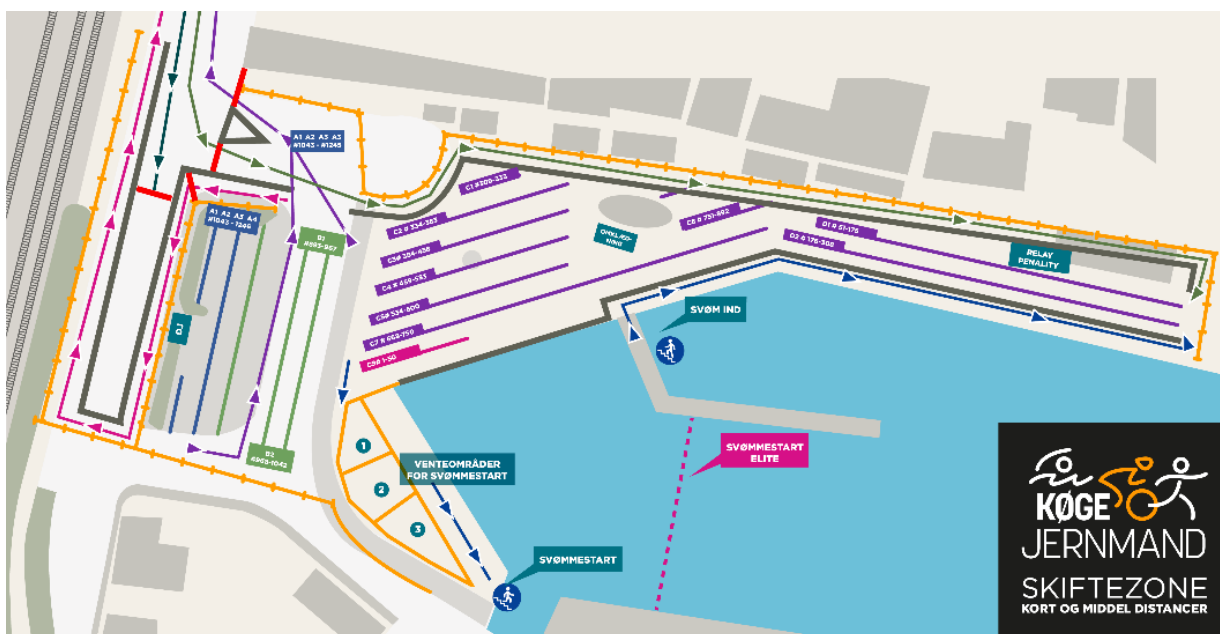

Figure 2: Transition area T1/T2

When you have finished the swim, you must follow the marked route from the bridge into the transition area. There will be officials to ensure that you go the correct way to the transition area.

If you swam in swimwear under your wetsuit and therefore wish to change into bike/tri clothing, this must take place in the transition tent, as nudity is not permitted outside the

transition tent. If, on the other hand, you wore clothing during the swim that you will also wear during the bike and/or run, it is optional whether the change takes place in the transition tent or by your bike.

Your wetsuit and any swimwear you do not wish to use on the bike leg should be placed in the transition box. It is recommended that you bring an extra bag for the wetsuit, etc., so that your other clothing and equipment do not get wet.

The bike helmet must be fastened on your head before the bike is removed from the rack. The bike must be pushed out of the transition area, and you may only mount it once you are outside the transition area and have passed the marked “mount line” when leaving T1, see Figure 2.

Læssøe Mandskab bike course

The bike course is hilly, especially on the first half, and is located west of Køge. From the transition area, the route heads north via the transport section to the lap course. The short distance completes one lap, while the middle distance and Aquabike complete two laps. Please note that the bike courses have been updated from 2025. The transport section to and from the bike course is shown in Figure 4, and the lap course is shown in Figure 5. GPX files can be downloaded here: [GPX Files](#)



Figure 4: Bike course, outbound and return from T1/T2



Figure 5: Bike course laps

Køge short distance:

The short distance completes the lap course shown in Figure 5 once, after which the route returns to the transition area. The total bike distance is approx. 46.5 km.

Køge middle distance & Aquabike:

The middle distance and Aquabike complete the lap course shown in Figure 5 twice, after which the route returns to the transition area. For Aquabike, this is the finish. The total bike distance is approx. 87 km.

No Pass and out of bars

When passing under the tunnel on Græsmarksvej after approx. 1.7 km and again at approx. 44 km and 86 km (marked with a red exclamation mark in Figure 6), you must pay special attention to poor lighting and uneven surface conditions. The area is therefore marked as a “No Pass” and “Out of bars” zone, which must be observed. Violations are penalized according to the Danish Triathlon Federation rules.

At the central median crossing on Zoffmannsvej and Ringvejen, a “No Pass” and “Out of bars” zone also applies. This is due to a small road bump when crossing the median.

Also be aware of the many full and half speed bumps on the bike lap, especially in the small villages. Some bumps are significant, so make sure bottles and other equipment are securely fastened so they do not fall off the bike.

OBS OBS OBS OBS OBS OBS

Vær særligt opmærksom ved jernbaneoverskæringen på Værftsvej til og fra skiftezone, da skinnerne kan være glatte.

Traffic on the bike course

Cycling takes place on public roads, which in most places are closed to regular traffic. However, there may be local traffic from residents within the route, and they have been informed to drive in the same direction as the cyclists. It is always your own responsibility to ride according to conditions, prioritize safety, and comply with traffic laws. At particularly exposed locations, experienced helpers will guide you, but pay special attention at:

- Road junctions / T-junctions
- Left and right turns
- Exits from private properties
- Large vehicles / agricultural machinery
- Aid stations

Drafting and overtaking

The bike leg must be completed without assistance from other participants, and drafting (riding on another athlete's wheel) is strictly prohibited. Always keep to the right side of the road and maintain at least 20 meters in the elite field and 12 meters in the age-group field. However, the 20-meter rule also applies if an age-group athlete overtakes and mixes into the elite field.

You may move left only when overtaking and must pass quickly. According to the Danish Triathlon Federation rules, an overtaking maneuver may take a maximum of 25 seconds. The overtaken participant must then drop back to 12 or 20 meters respectively before a new overtaking attempt may begin. Overtaking may take place only on the left. Passing on the right results in a penalty. It is therefore important that you keep right so other participants can comply with the rules.

Officials may issue yellow, blue, and red cards if a situation cannot be resolved with a warning. A blue card is given for drafting and carries a 2-minute time penalty in the "Penalty box" for both distances in accordance with the Danish Triathlon Federation competition rules. Other offenses are penalized with 30 seconds. It is the athlete's own responsibility to report for serving a time penalty at the Penalty box, which is located on the opposite side of the aid station on the bike course at km 43.5 + 83.5. If you receive a penalty on the final part of the section back toward the transition area, it is served in the "Penalty box" on the run course.

Music

It is not permitted to use an MP3 player, phone, or any other music player on the bike course for playing music. For your own safety and that of others, you must be able to hear traffic and your surroundings. Phones may be used for relevant applications, but headphones may not be used.

Officials

There will be officials on the bike course to ensure that the race rules are followed. Their instructions must always be followed. Officials can issue both warnings and penalties if the rules are not observed. Penalties may be given to both individuals and groups of triathletes. There will be a penalty box on the bike course just before the turnaround and on the opposite side of the Enervit aid station after approx. 42 km. Warnings, stop-and-correct-continue orders, or on-the-spot time penalties may also be given. Repeated penalties may lead to disqualification.

It is your own responsibility to serve the penalty and notify an official so your number can be recorded upon arrival.

Enervit aid station on the bike course

There is one aid station on the bike course, which you pass on each lap. The aid station is located on Ølbyvej shortly after you have entered the lap course, i.e. after approx. 3.5 km and 43.5 km; see the blue marking in Figure 6. If you do not use the aid station, you must bring the fluid and energy you need for the first lap of the bike course yourself.

Please note: the short distance passes the aid station only once, after approx. 3.5 km.

At the aid station there will be products from Enervit, including sports drink, electrolytes, gels, and water.

Approx. 300 meters before the aid station, there is a “drop zone” where you can discard your used bottles. After that, you will receive new bottles with sports drink or water.

Please note that you must bring your own energy bars for the bike course as needed.

Transition area, T2

When the bike leg is completed, you arrive at the transition area. You must dismount before the entrance to the transition area at the marked “dismount line”, see Figure 2, and then follow the route into T2.

You must keep your bike helmet on until the bike has been returned to the rack. The bike must be placed in the same spot where it stood before the start and where your transition box is located.

Before you continue onto the run course, you must attach your race number if you did not already wear it during the bike leg. The race number must be worn visibly on the front of the body, either on your top or on a race belt. A race belt may be an advantage in transition, but it is not required.

If you wish to change clothes, you must use the transition tent in the transition area. Please note that nudity is not permitted outside the transition tent.

Bike course cut-off

The bike course cut-off is 13:00 for the short distance and 16:00 for the middle distance. Triathletes who return to the transition area later than this will not be allowed to continue onto the run course.



Bryggeri Skovlyst - Run course

All runners must have left T2 by 16:10. Otherwise, the participant may not continue. The route starts from the harbor, see Figure 6, and heads into town. After just under 5 km, the middle distance continues straight ahead, while the short distance turns right toward the station; see the exclamation mark in Figure 6. The run course goes through Køge town, where you pass historic buildings, courtyards, and the town square. The surface is a mix of asphalt, sidewalks, cobblestones, and in a few places gravel. The finish is at Kulturtorvet, where you will receive a warm welcome after what is hopefully a hard but great day. The run routes are available in GPX format here: [Run course](#)

Figure 6: Run course

The short distance completes 3 laps. This means that the 4th time you see the finish area at Kulturtorvet, keep right to run around Køge Cinema before running the final meters up the finishing straight to the finish line.

Remember: continue toward the finish when you have run approx. 10 km. For each lap, you will receive a wristband to be worn on your wrist.

The middle distance completes 5 laps; note the longer lap. This means that the 6th time you see the finish area at Kulturtorvet, keep right to run around Køge Cinema before running the final

REMEMBER: continue toward the finish when you have run approx. 20.5 km. For each lap, you will receive a wristband to be worn on your wrist.

Aid stations

There are two aid stations on the run course; see Figure 6. Both distances pass the large aid station at Kulturtorvet on every lap, while the middle distance also passes a smaller aid station at KØS, Nørregade. You encounter the first aid station after approx. 2.6 km.

Distance from T2	Aid station name	Course
2.6 km / 2.6 km	Kulturtorvet	Short + middle
5 km	KØS, Nørregade	Middle
5 km	Kulturtorvet	Short + middle
8.8 km	KØS, Nørregade	Middle
7.8 km / 10.1 km	Kulturtorvet	Short + middle
12.5 km	KØS, Nørregade	Middle
13.9 km	Kulturtorvet	Middle
16.3 km	KØS, Nørregade	Middle
17.6 km	Kulturtorvet	Middle
19 km	KØS, Nørregade	Middle

Due to the short laps on the run, the two aid stations offer different supplies:

At the large aid station at Kulturtorvet, there will be a selection of bananas, sports drink (Enervit), and water. At the small aid station at KØS, Nørregade, ONLY water will be served.

Litter and penalty

It is only permitted to discard litter at the aid stations. Please consider the environment and the residents along the route throughout the event.

For Elite, penalties are served in the Penalty box established on the run course.

There will be a penalty box on the bike course just before the turnaround and on the opposite side of the Enervit aid station after approx. 42 km. Warnings, stop-and-correct-continue orders, or on-the-spot time penalties may also be given. Repeated penalties may lead to disqualification.

Run course cut-off

The run course cut-off is 18:00, when the finish area closes. If it is assessed that a participant cannot complete the final lap in time, they may be stopped before being allowed to start the last lap.

Signage

The routes will be clearly marked with signs, small flags, running lanes, and flag marshals. However, it is the participants' own responsibility to keep track of the number of laps they have completed.

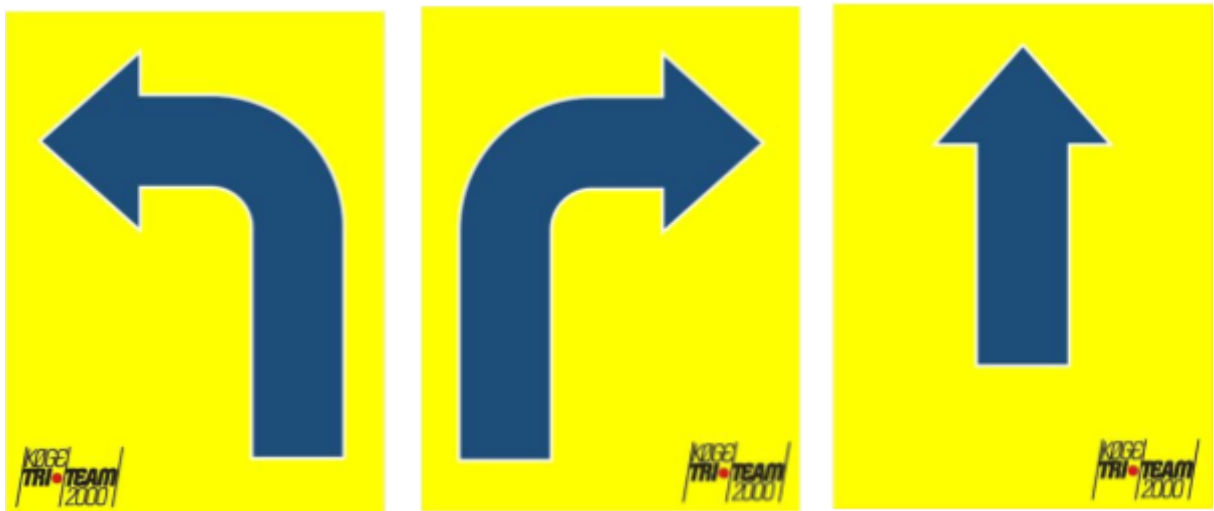

Spectators

On the swim course, there is a great view of both the start and the course from the harbor mole.

On the bike course, Græsmarksvej to Nørre Boulevard is a good place to follow the participants. The speed is not very high here, so you have a good chance to see the riders up close and perhaps take a few photos.

On the run course, there are good opportunities to cheer on the participants, especially in Køge town and at Kulturtorvet. This is where you will find the finishing straight, and participants pass through the area several times during the day.

Køge offers great opportunities for both food experiences and city life while the participants are out on the course. We therefore encourage all visitors to also take time to experience the town along the way.

Please feel free to stay by the transition area and follow our strong Aquabike participants competing for the Danish Championship. The finish area for this distance is located just outside the transition area.

Spectators can follow participants' times via Sportstiming and its app for both Android and Apple.

Return of the timing chip.

When you have completed the race, we ask you to return the timing chip in the designated box before you leave the athlete area. If it is not returned, a charge may be invoiced afterwards.

Race organizer / Disclaimer

Køge Tri Team 2000 is the official organizer of Køge Jernmand. Participation in the event is at your own risk, and Køge Tri Team 2000 cannot in any way be held responsible for injuries or losses that participants may cause to themselves or each other. Køge Tri Team 2000 cannot be held liable for damage to or theft of participants' equipment, bicycles, property, etc.

Køge Tri Team 2000 has taken out organizer liability insurance covering the liability Køge Tri Team 2000 may incur as organizer of Køge Jernmand.

Sponsors

Last but not least, we would like to extend a big thank you to SJF Bank and Køge Municipality as well as all our sponsors who have made the event possible. Without you, we would not have an event. At the risk of having forgotten a sponsor or two, we are taking the chance and mentioning them by name here. A big thank you goes to: